

# Installation, Operation and Maintenance Manual of Dual Plate Check Valves

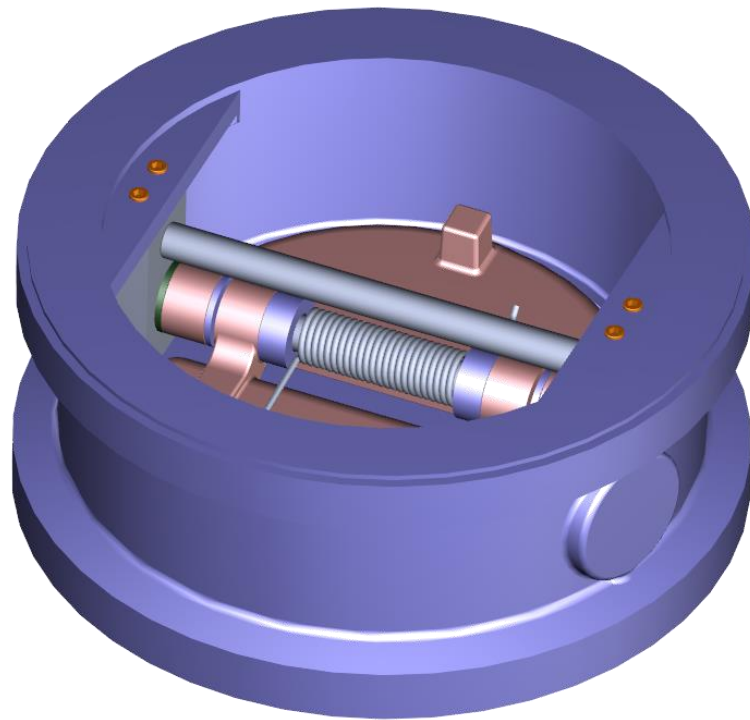

<b>Contents</b>	<b>Page No.</b>
<b>L&amp;T Valves</b>	<b>3</b>
<b>Dual Plate Check Valves</b>	<b>4</b>
<b>Exploded View</b>	<b>5,6</b>
<b>Delivery Condition</b>	<b>7</b>
<b>Handling and Storage</b>	<b>8</b>
<b>Planning and Responsibilities</b>	<b>9</b>
<b>Valve Installation</b>	<b>10,11</b>
<b>Valve Operation</b>	<b>12</b>
<b>Do's and Don'ts</b>	<b>13</b>
<b>Maintenance</b>	<b>14</b>
<b>Dismantling and Assembly Procedure</b>	<b>15</b>
<b>Troubleshooting</b>	<b>16</b>
<b>Appendix</b>	<b>17</b>

## L&T Valves

L&T Valves Limited (formerly Audco India Limited) is a wholly-owned subsidiary of L&T and one of the largest valve manufacturers in the world.

The company has three modern manufacturing facilities, in Chennai (Manapakkam), Coimbatore and Kancheepuram, in Tamil Nadu, India. The company leverages its world-class capabilities in design, quality assurance and manufacturing to ensure that their products consistently meet customer expectations.

### **Product Range:**

- Gate, Globe & Check Valves
- Valves for Power
- Pipeline & Process Ball Valves
- Triple-offset Butterfly Valves
- Rubber lined Butterfly Valves
- Valves for Water Service
- Double Block & Bleed Plug Valves
- Control Valves
- Customised Solutions

Designs for the valves are created by an experienced team of valve experts who have a deep understanding of user-industry processes. An extensive manufacturing and quality assurance infrastructure ensure that world-class designs are transformed into high performance products. Every phase of manufacture is governed by an institutionalised environment, health and safety policy.

L&T Valves distribution network spans across the globe, partnering some of the largest valve distribution companies in the world. In India, L&T Valves has a presence in every industrial centre through a network of offices, stockists, automation centres and service franchisees

## Dual Plate Check Valves

The Dual Plate Check Valves are all purpose non return valves that are much stronger, lighter in weight and smaller in size compared to conventional swing check valve or lift check valve. They are ideally suited for flowlines, manifolds, pipeline transmission and distribution, pressure regulation and metering runs, underground storage, hot tapping, water flood and general pipeline service.

Dual Plate Check valves are offered in cast construction. Valves are with single piece body construction either with flanged /butt weld/wafer/Solid lug ends. The Dual Plate Check Valve employs two-spring-loaded plates hinged on a central hinge pin. When the flow decreases, the plates close by the action of torsion spring before flow reversal takes place.

### Design Features

- No Water Hammer
- No Slamming
- Retainerless Design for Fugitive Emission Control
- Lower pressure drop
- Lower wear and tear of seat faces
- Flexible installation

All features put together make the Dual Plate Check Valve as the most efficient and versatile design.

### Range

Size	Pressure Class Rating
2"-36" (50 mm to 900 mm)	150
2"-36" (50 mm to 900 mm)	300
2"-30" (50 mm to 750 mm)	600

Exploded View: 2"-12" (50 mm to 300 mm)

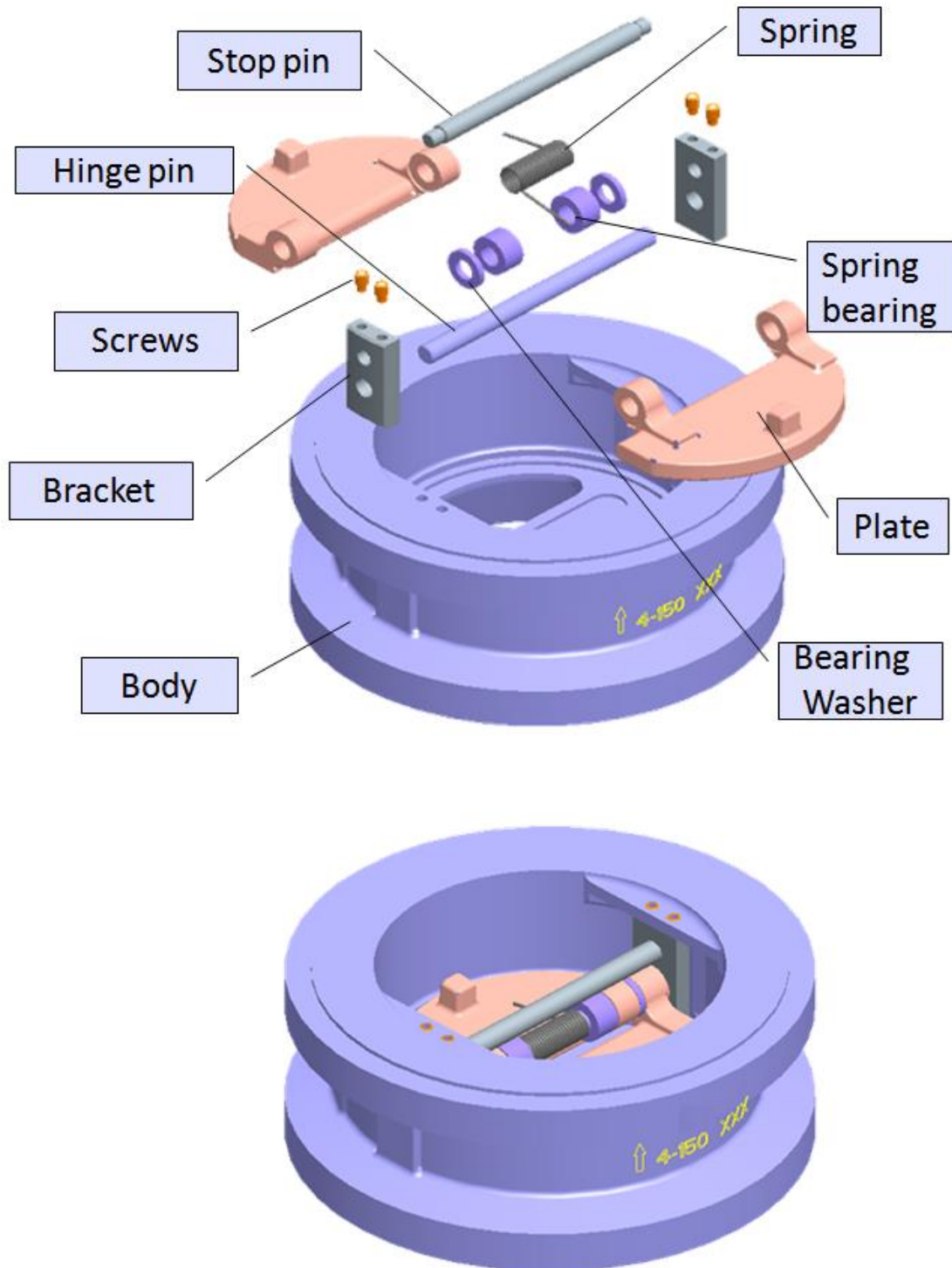

Fig 1

Exploded View: 14"-36" (350 mm to 900 mm)

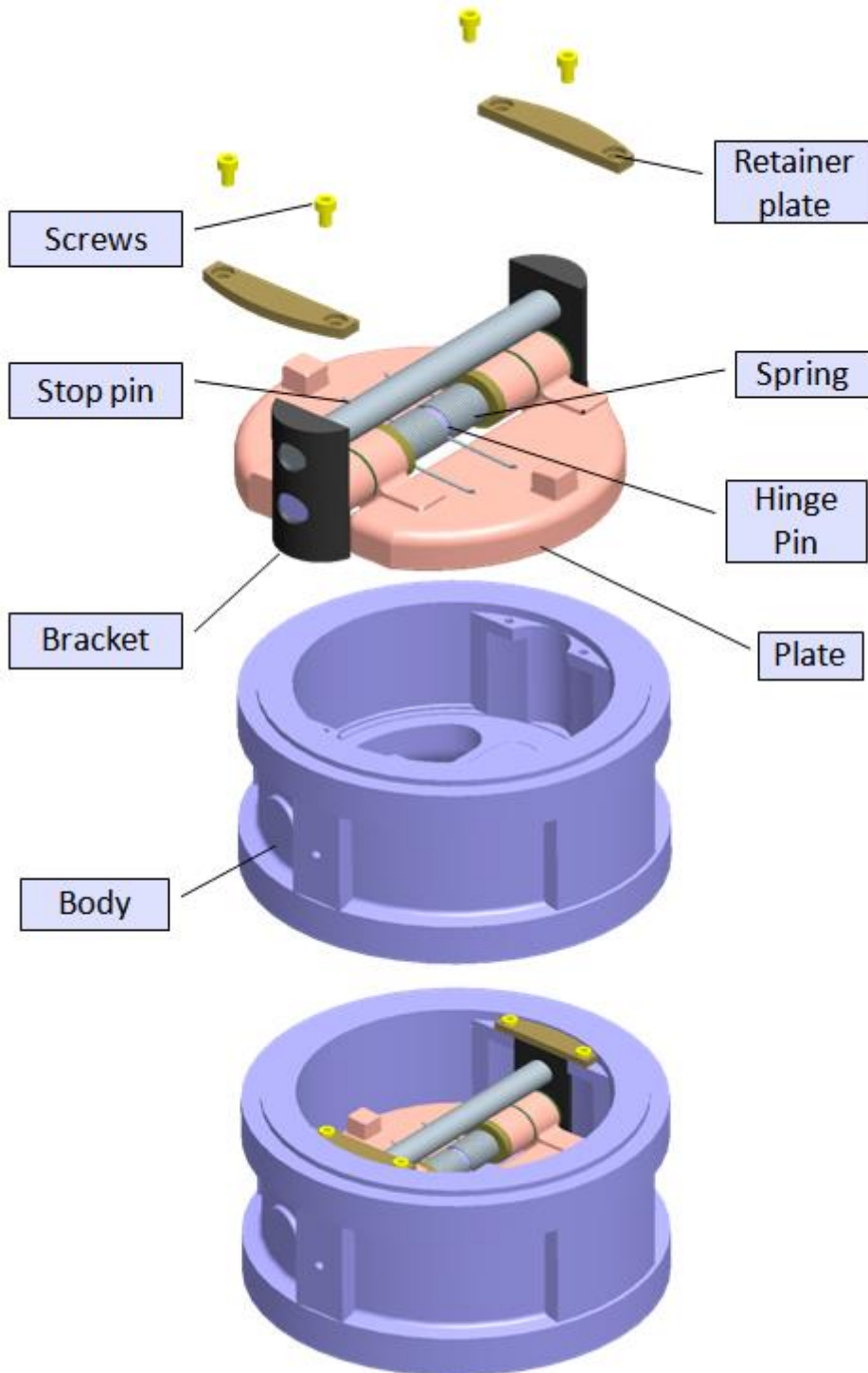

Fig 2

## Delivery Condition

Valves are shipped with the disc in a fully closed position, such that the metal seats are under compression in order to avoid damages of both body & disc seat faces. Orientation of the valve may be either horizontal or vertical depending on the shipped valve dimensions. Please check the packing slip attached to the container before opening the same.

Valve identification details can be found on the name plate and on the body of the valve (cast design). A typical identification plate is shown in Fig 3.

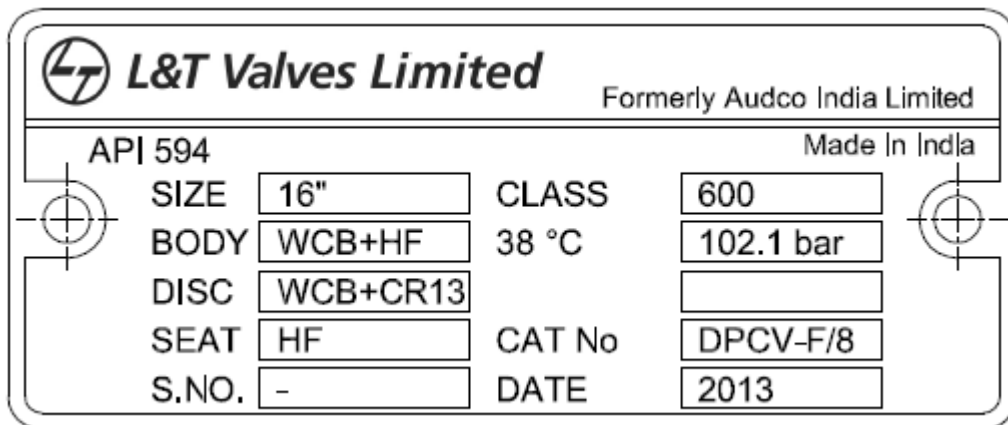

Fig 3

Valves are supplied with end protectors for avoiding damage to internals.

## Handling and Storage

### Handling

Valve shall be properly supported and secured before moving, to prevent possible damage to valve and property or harm to personnel.

Do not drag the valve on the ground while transporting. A minimum of one foot height from the ground is to be maintained while moving the valve.

Valve shall not be slung around the valve port for transportation. Lifting lugs are provided for this purpose on the valves.

If metal chains are used, ensure all gasket faces are protected from potential scratches & gouges.

### Storage

Clean the yard and ensure that the end protectors are in place before the valve is stored, as dry contaminants like dust, sand, grit etc. can scratch metal seating surfaces and the soft parts, leading to leakages during operation.

Valves shall be stored in covered area which is dust free, least humid and well ventilated.

The valve shall always be maintained in an ambience with temperature higher than the dew point temperature at the storage location, so as to avoid collection of water droplets on the valve surface.

Do not keep the valve directly on the floor. Valve shall be placed on wooden pallet such that it is at least at a height of 150 mm (6 inch) from the floor.

Do not apply tar, grease or any other material inside the valve, as it could impair the performance of the valve.

When flange protectors are supplied on the inlet and outlet gasket faces, they should stay on the valve until it is ready for installation.

Improper storage and /or handling may cause disc/seal damage or deformation of shaft or seat, which will affect sealing and operational performance of the valve.



## Planning & Responsibilities

When installing or maintaining valves

- Conduct a risk assessment and eliminate or reduce hazards to an acceptable level.
- Work in accordance with safe systems of work site.
- Observe all site health and safety rules.
- Wear all necessary personal protective equipment.
- Never use a valve on a duty which exceeds its prescribed operating parameters. Refer to L&T Valves for further information.
- The valve shall not be subjected to frequently occurring disturbances.
- End user to ensure there are no external disturbances (e.g. Shocks, vibrations, electromagnetic fields etc.)
- Misuse of valves / valve components are strictly prohibited.
- Maximum surface temperature of the equipment will be same as the line media temperature. The end user must take account of the line media temperature.
- If the processes or environments that the valves are used in are likely to cause temperatures (high or low) that may cause injury to personnel if touched, then adequate insulation / protection must be fitted.
- Adequate safety measures shall be made for valves similar to pipe lines.
- Due to variety of duties in which these valves can be employed, it is the end user's responsibility to ensure the compatibility of media with the material of construction of the product for each specific application (i.e. corrosion and erosion which may affect integrity of the pressure containing envelope).
- Before valves are installed in areas which may be subject to seismic activity or extreme climatic conditions, consult L&T Valves with data.
- All exposed parts shall be cleaned to prevent dust deposit or insulation is needed similar to pipe line.
- Valves should be protected by other devices to prevent over-pressurisation. (i.e., caused by temperature, fire etc.).

## Valve Installation

### General

Carefully unpack the valve and check for tags or identification plates, etc.

- If the identification plate / arrow plate / tag is lost or destroyed during the shipment or while in storage or if it is not legible, contact your distributor or L&T Valves
- Look for any special warning tags or plate attached to or accompanying the valve and if any, take appropriate action.
- It is recommended to remove all foreign particles from the pipe line by flushing it with a suitable fluid. Corrosion inhibitors shall be added to the flushing medium to prevent any corrosion due to trapped fluids.
- Remove the end protectors and protective sheath within the flow bore valve, wherever provided.
- Gasket contact faces of the valve and pipe flanges shall be inspected thoroughly for scratches / defects. Scratches, if any, shall be corrected by grinding the surfaces or by rubbing with emery sheet.
- The pipes must be properly aligned and provisions made to minimize stresses from external load/thermal expansion. Always review pipe manufacturer's recommendation.
- In case of pipes with long overhangs, adequate support/jacks shall be provided at the flange ends of the pipe so as to avoid bending of pipes due to weight of the valve.

The improper alignment of the pipe and the valve during installation can lead to unbalanced tightening of the flanges which may cause excessive stress on the bolts and lead to leakage

- Refer [Appendix A1](#) for applicable standards
- For handling refer relevant section on [Handling and Storage](#)
- Please refer to the arrow plate attached to the valve body for preferred direction of flow
- Clean valve flanges and companion flanges and remove protective grease from the valve flanges. Clean the valve interiors adjacent piping prior to mounting of the valve pipe joint
- Check all surfaces for cleanliness and other visible sign of foreign matter as the internal surfaces/parts must be clean and free of debris before installation
- Ensure that the valve is in fully closed position during installation
- Align the bolt holes of the valve end flange and pipe flange. Insert the gasket (not supplied with valve) and tighten the bolts. Flange bolts shall be tightened evenly. Using suitable device, in cross rotation to prevent damage to the flange.
- Bolts should be lubricated for ease of installation
- For sequence of tightening bolts, refer [Appendix A2](#)
- Check valves should be installed a minimum of 5 pipe diameters downstream of any piping component (elbow, Tee, Valve, etc.) to allow the flow to stabilize. There should also be a minimum of 2 diameters of straight pipe downstream of the valve before the next fitting to allow for pressure recovery.

If valve is not cleaned or if cleaning is done after valve installation cavities may form a natural trap in the piping system. Any impurity not dissolved or washed out by the flushing fluid/line fluid may settle in such cavities and adversely affect valve performance.

- In horizontal flow installation, the hinge pin must be vertical.

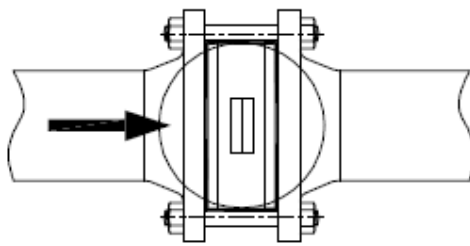

Horizontal pipe

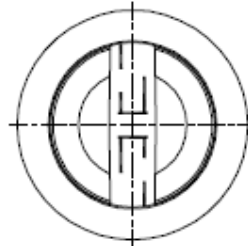

Horizontal pipe

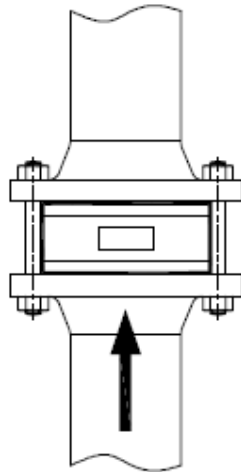

Vertical pipe with flow UP.

No Restriction

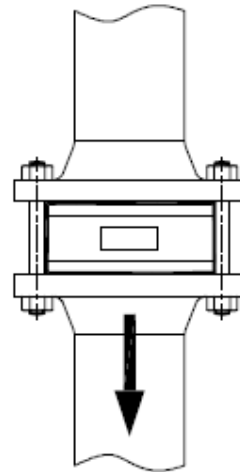

Vertical pipe flow DOWN.

Not Recommended

Fig-4

## Valve Operation

### General

- Operational life of the valve can be maximized if the valve is used within the rated range, in accordance with design parameters.
- For understanding the internal construction refer to the general assembly drawing of the valve. Dual plate Check valves require correct positioning of the closure element to seal properly.

### Operation Mechanism

The Dual plate check valve has two semicircular D-shaped closure plates (2) loaded with torsion spring (5) and hinged on a central hinge pin (3) such that they can swivel freely about the axis of the hinge pin. The hinge pin with the spring and plates are supported by two brackets (6) on either side and mounted on the body (1). Brackets also retain the stop pin (4) provided above the hinge pin to prevent the closure plates sagging beyond the desired opening. The hinge pin, stop pin, torsion spring and closure plates assembled with the bracket and then the whole assembly is lifted and inserted perpendicular to the body bottom rib (1a) and then rotated to 90 degrees such that the brackets are located below the lug (1b) provided in the body. The bracket carrying the whole assembly was retained by the lug using screws (7). Bearing washers (8) are provided in between the plates for smooth swiveling action. Spring bearings (9) also provided to prevent the motion of the spring.

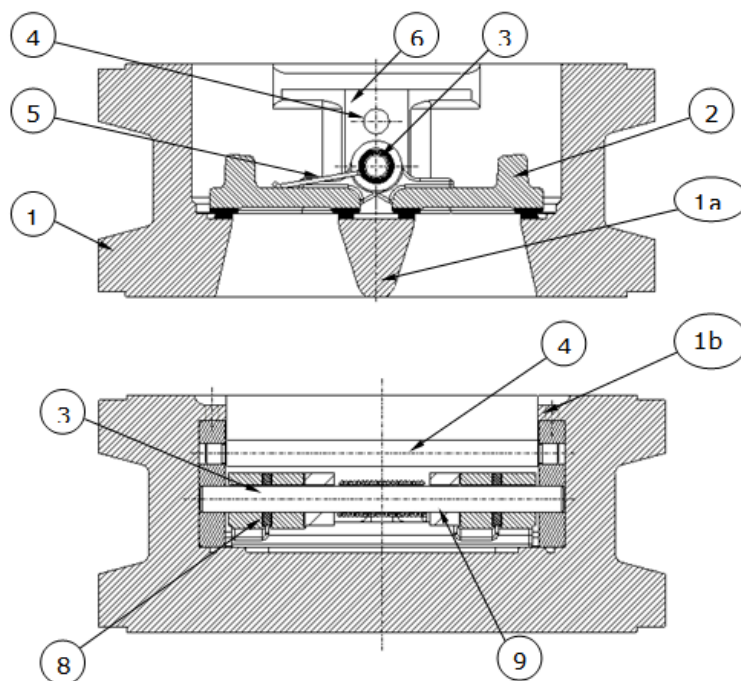

Fig-5

## Do's and Don'ts

### Do's

Before taking valve for erection, make sure that is cleaned properly from inside and outside and there are no foreign particles or metallic chips sticking on to sealing element

Carefully read the identification plate details and install the valve in the right place and for the correct duty conditions for which it is designed and manufactured. Dual plate check valves have preferred sealing direction marked by an arrow on the valve body side.

Make sure to remove the entire rust preventive on the machined surface in the flow area before a valve is put in the pipe line.

Ensure there is no pressure while dismantling the valve for maintenance.

### Don'ts

DO NOT install a valve very near elbows, pumps, tees, expansions, etc.,

DO NOT use end flange holes to lift the valve.

DO NOT install valve for flow from top to bottom (Closure plates hanging downwards)

DO NOT used for service condition for which it is not intended for.

## Maintenance

### Introduction

For enhanced life of the valve and better operability, it is recommended to do a periodic inspection and maintenance of the valves as per the procedure explained below:

It is advisable to maintain a record of the performance of the valve.

Improper installation, insufficient flow, Turbulent flow and location of valve with respect to the pump will cause severe damage to the internal components of the valve.

### Safety Procedure

Always depressurize the pipeline when taking up any maintenance activity on the valve.

Study carefully and understand the instructions outlined in the installation, operation & maintenance manual of the valve before taking up any maintenance.

### Routine Maintenance

The following activities can be carried out during the routine maintenance of the valves.

- Ensure no body damage or any external leakage through body wall.
- Ensure the valve gasket faces are not damaged.
- Ensure the disc movement are not restricted.
- Ensure there are no gouge marks on the Hinge pin or Disc from the Spring component.
- Inspect the body and disc seating surfaces to ensure no gouges or scratches.
- Ensure there is no damage to the Spring bearing component.

*Note: After Maintenance of the Dual Plate Check Valve, and before commissioning the same, please observe all the installation guidelines as mentioned in Valve Installation section.*

## Dismantling and Assembly Procedure

### Dismantling Procedure

- Depressurize the line and open the valve to drain the line
- Valves shall be slung properly and supported before loosening companion flange bolts.
- Place the valve in platform or base and transport to the repair shop. Refer GA drawings / Exploded view for component identification
- Lay valve down with the downstream side of the valve upward.
- Remove the retainer screws, retainer plates.
- Rotate the entire Sub assembly to 90°, lift the sub assembly from the body seat face.
- Remove the bracket from sub assembly.
- Remove Hinge pin and Stop pin while holding the springs firmly.
- Remove the springs, plates & bearings.

Carry out the required replacement of the parts and reassemble the valve with new parts

### Assembly Procedure

- Visually inspect all the components (viz. Body, Disc, Shaft, Grooved pins, etc.,) and ensure that they are clean and free from rust, damage, cut marks, and ensure all the machining operations are completed.
- The entire valve assembly consists of a Body and a sub-assembly which consist of Trim components such as closure plate, hinge pin, stop pin, bracket, bearing washer, spring bearing and socket set screws.
- After the two closure plates are placed oppositely in order to align the hinge boss holes in the same axis, the hinge pin is inserted via a hinge boss at the end of one of the closure plates, bearing washer, hinge boss of the other closure plate, spring bearing, torsion springs, spring bearing and again torsion spring, spring bearing, other hinge boss of the former closure plate, bearing washer and hinge boss at the end of the other closure plate.
- The bearing washer has to be placed on both ends of the hinge boss face. Then one of the brackets is inserted at one end of the hinge pin which closes the bearing washer at end.
- Next the stop pin is inserted in the hole provided in the bracket. Then another bracket is inserted at the other end of the hinge pin and stop pin which closes the entire sub-assembly.
- Then the entire sub-assembly inserted into the body and rotated by 90°. In order to align the top surface of the bracket hole and the tapping in lug of the body. After the alignment, the socket screws have to be fastened to keep the body and sub-assembly intact.
- For the sizes above 12", entire sub-assembly can be inserted from the top surface without any rotation. After the alignment, Socket screws have to be fastened over the retainer plate to keep the body and subassembly intact.

## Troubleshooting

<b>Problem</b>	<b>Reason</b>	<b>Action</b>
Leakage through end joints	End Flange bolting loose	Tighten the bolting
	Gasket damage	Replace the gasket
Seat leak	Seat surface damage	Dismantle and lap the seat surface
	Spring tension loss	Dismantle and verify spring tension
Vibration	Excess flow	Verify the flow rate is within range
	Valve installed very closed to turbulence producing devices (elbows, pumps, tees, expansions, etc.,)	Verify that the Check Valve is 5 to 10 pipe diameters from any turbulence producing devices
Flow halted at check valve	Wrongly assembled	Reinstall and verify that the flow direction arrow which is marked on the side of the body is pointing in the direction of the flow.



## Appendix

### A1 - References

#### Design Compliance

API 594	Check Valves: Flanged, Lug, Wafer, and Butt-welding
---------	--

#### Face to Face Dimensions

API 594	
---------	--

#### End Connections

ASME B16.5	Pipe Flanges and Flange Fittings (NPS ½ through NPS 24)
ASME B16.47	Large Diameter Steel Flanges (NPS 26 through NPS 60)
ASME B16.25	Butt Welding Ends

#### Testing Standard

API 598	Valve Inspection & Testing
---------	----------------------------

## A2 - Tightening Sequence & Torque

The tightening sequence for all possible number of End flange bolting is beyond the scope of this manual. However, the logic to be followed is explained below

- Tighten the first four nuts in the sequence shown Fig.6. This helps in correct location of the mating parts.
- Tighten the other bolts in the sequence shown Fig.7 the same way.
- The sequence goes clockwise around the bolt
- Ensure that the recommended torque (refer Table1&2) is maintained in all bolting.

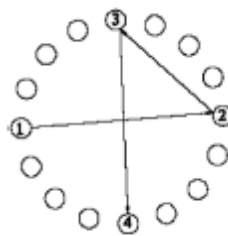

**Fig. 6 Initial Tightening**

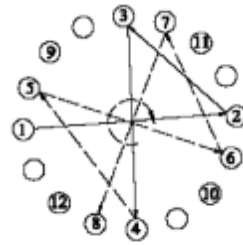

**Fig. 7 Sequence of Tightening**

**Table 1 Tightening Torque values for Carbon steel bolting**

Thread size	Torque (+/- 10%) (Nm)
M8	16
M10	32
M12	57
M16	140
M20	274
M24	473
M27	693
M30	940
M33	1280
M36	1644

**Table 2** Tightening Torque values for Stainless steel bolting

Thread size	Torque (+/-10%) (Nm)
<b>M8</b>	<b>8</b>
<b>M10</b>	<b>15</b>
<b>M12</b>	<b>26</b>
<b>M16</b>	<b>65</b>
<b>M20</b>	<b>127</b>
<b>M24</b>	<b>219</b>



---

*L&T Valves Limited*  
Mount - Poonamallee Road, Manapakkam, Chennai 600 089, INDIA  
Tel. : + 91 44 2249 8201 Fax: +91 44 2249 2794 [contactus@Lntvalves.com](mailto:contactus@Lntvalves.com)  
[www.Lntvalves.com](http://www.Lntvalves.com)

Document No : LTV-DEP-559-R0/0314  
As we continuously endeavor to improve our products, the data given herein is subject to change. Please refer [www.Lntvalves.com](http://www.Lntvalves.com) for the latest IOM.